

Moshabak Sazan Arya

| Grating & Stair Tread

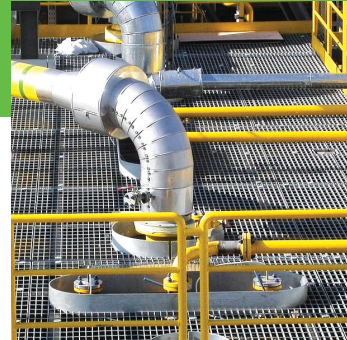

جای پاتو محکم کن

www.gratingmsa.ir

مشبک سازان آریا (سهامی خاص) —

این شرکت از سال ۱۳۸۴ در زمینه تولید گریپتینگ و پله فلزی فعالیت خود را آغاز نموده است و در حال حاضر با در اختیار داشتن کادری مجرب و متعهد و امکانات کافی نیازهای مشتریان را به بهترین شکل پاسخ می گوید. این شرکت در زمینی به مساحت ۳۶۰۰ متر مربع و در دو کارگاه به مساحت ۱۳۰۰ متر مربع توانایی تولید روزانه ۲۰ تن گریپتینگ را دارا می باشد. لازم به توضیح است این شرکت در تولیدات خود هیچ گونه محدودیتی نداشته و می تواند سبک ترین گریپتینگ های صنایع شهری را تا سنگین ترین گریپتینگ های مخصوص بنادر و سیلوها را تولید نماید.

Moshabak Sazan Arya Co. —

The company has began its operation since 2005 in the field of grating and stair tread manufacturing and now is equipped with skill full and committed staff and suitable facilities to try its best in response to the customers requirement.

The company in the location with 3600 m² area and in two workshop with 1300 m² area has the needed capacity to produce 20 tons day grating. It is worth mentioning that the company has no limitation in its production and is able to manufacture the lightest grating used in the urban industries and the heaviest gratings for silo and port applications.



گرتینگ فلزی (فولادی)

بیشترین مصرف گرتینگ از این نوع می باشد که بدون هیچ گونه محدودیتی قابل ساخت می باشد. کلیه مشخصات گرتینگ های تولیدی این شرکت مطابق با استانداردهای زیر می باشد.

ANSI/NAAMM MBG 531
ANSI/NAAMM MBG 532
BS 4592
DIN 24531

Metal Bar grating (steel)

This type of grating has the highest consumption rate which is manufactured without any limitation all of the company produced gratings have the following standard specifications:

ANSI/NAAMM MBG 531
ANSI/NAAMM MBG 532
BS 4592
DIN 24531

گرتینگ استنلس استیل

با استفاده از جوش آرگون و ورق استیل ۳۰۴ تولید می گردد و مناسب ترین گزینه برای محیط های بهداشتی و صنایع غذایی می باشد.

Stainless steel grating

This type of grating is manufactured using argon welding and steel sheet 304 and is the most appropriate option for applications in hygienic environment and food industries.

پوشش گالوانیزه

مطابق با استاندارد ASTM A123 و با حداقل ۸۰ میکرون ضخامت پوشش و انجام کلیه تست های مربوط به پوشش روی.

Galvanized coating

It is according to ASTM A123 with minimum thickness of 80 mic which is passed through all coating tests.

www.gratingmsa.ir

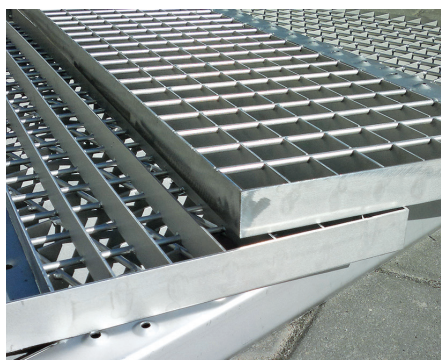

Grating Terminology

Load Bearing Bar

A load-carrying member spanning between supports.

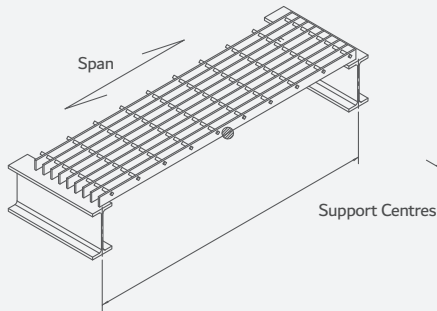

Length (Direction of Span)

The overall dimension of a panel parallel to the load-bearing bars.

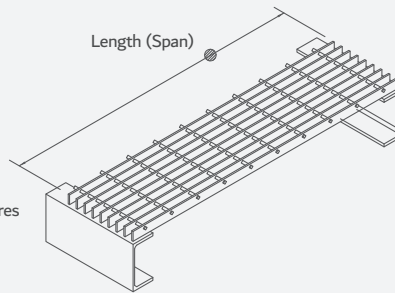

Nosing Bar

A member attached to the front edge of a stair tread or top stair landing panel.

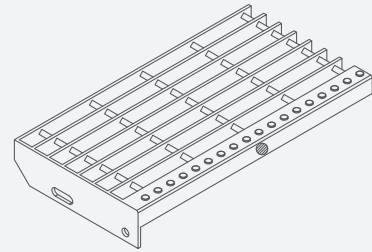

Cross Bar

A member fixed at right angles to the load bearing bars to provide lateral restraint.

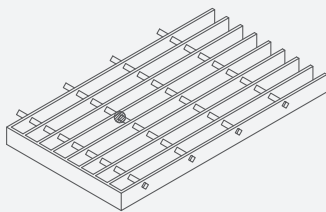

Width

The overall dimension of a panel at right angles to the load-bearing bars.

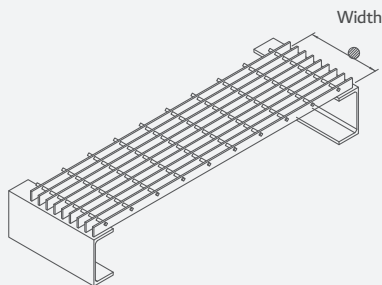

Kick Plate

A large, flat bar welded to the side of a panel or ends and around cut-outs, where specified. Nominally 100mm above walking surface.

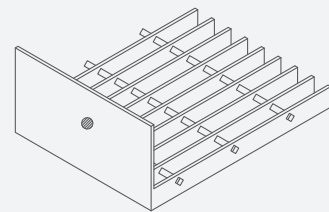

Edge Bar

Non-load-bearing bars, running at right angles to the load-bearing members.

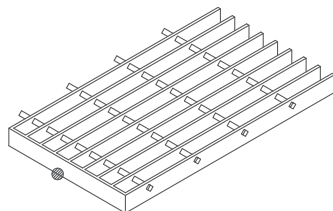

Serrations

Notches formed in the top of load-bearing bars to improve slip resistance.

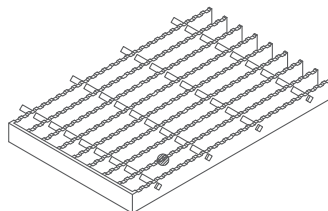

Cut-Outs

Area of flooring removed to clear around columns, pipes, machinery, etc.

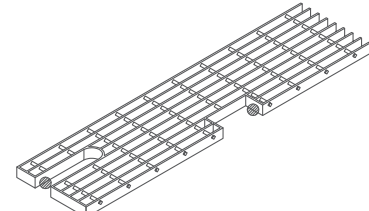

Nett Area

The area of flooring remaining after deducting cut-outs $([A \times B] - [C \times D])$.

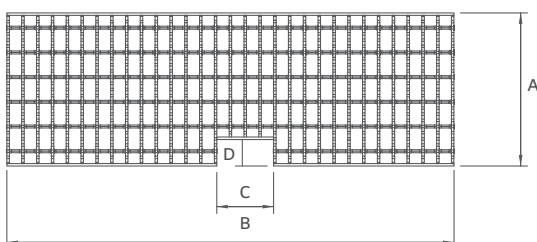

Gross Area

Total area of flooring, including cut-outs $(A \times B)$.

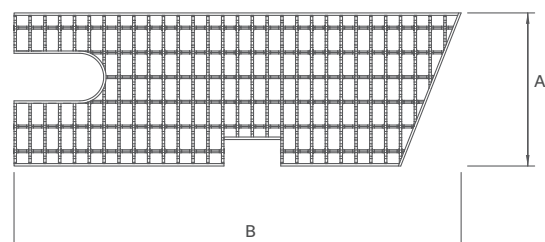

Grating categories

Moshabak Sazan Arya gratings are manufactured in standard stock sizes. these panels are then fabricated to suit specific applications

Standard steel panel sizes

Safegrid 1 m × 6m(nominal)

N : 1000 × 6000 mm

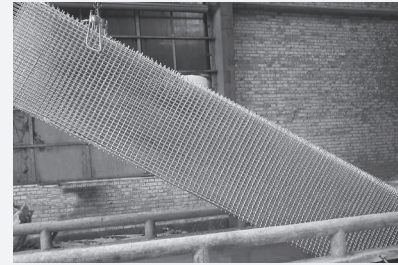

Rectangular fabricated grating

Cut and bind

- a** standard width panels.
- b** runs of panels can have 1 no. made to width panel i.e. a panel which is smaller or bigger than the standard width to make up the walkway overall length.
- c** no cut-outs or panel notching.
- d** panel ends bound with binding bars of the same depth as the bearing bars.
- e** toe plate can replace binding bars at additional cost
- f** most cost effective fabrication

simple layout

- a** generally standard width panels, but areas supplied with non-standard widths to suit application.
- B** nominal amounts of panel shaping and cut-outs.
- C** panel ends and cut-outs bound with binding bars of the same depth as the bearing bars
- D** toe plate can replace binding bars at additional cost.

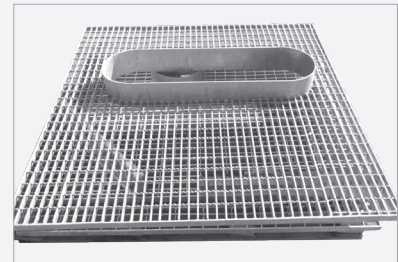

Annular fabricated grating

- A** generally standard width panels, but areas supplied with non-standard widths to suit application.
- B** large amounts of panel shaping and cut-outs.
- C** panel ends and cut-outs bound with binding bars of the same depth as the bearing bars.
- D** toe plate can replace binding bars at additional cost.

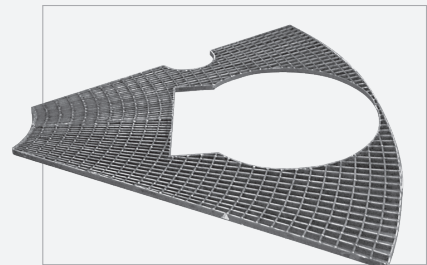

All flooring is manufactured from material grade S275JR as standard. other materials are available on request. Moshabak Sazan Arya flooring is available in either:

Self colour Allows for on-site fabrication and improved delivery times.

Galvanized hot dip galvanized to BS EN ISO 1461, ASTM A123 or other international hot dip galvanizing standards. surface preparation by blasting to sa 2 1/2 when required will be charged extra.

Installation clearances

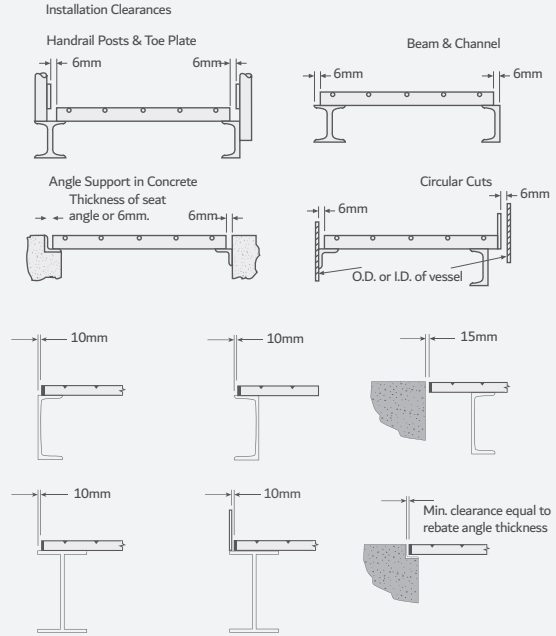
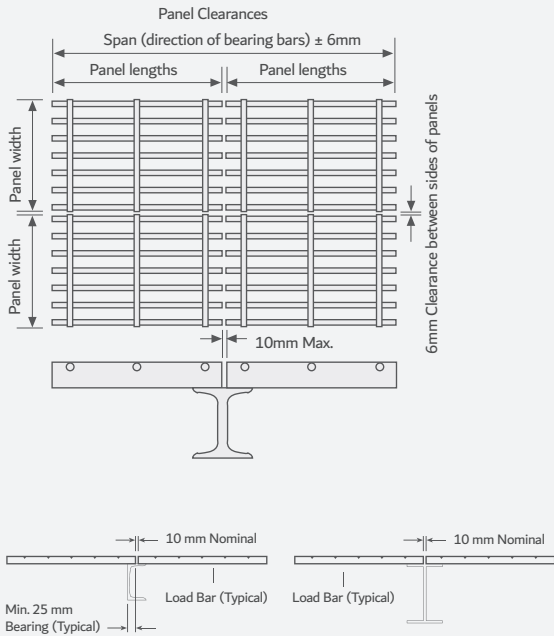

Note :
Clearance can vary relative to straightness of rebate angle

All dimensions given are maximum permissible tolerances

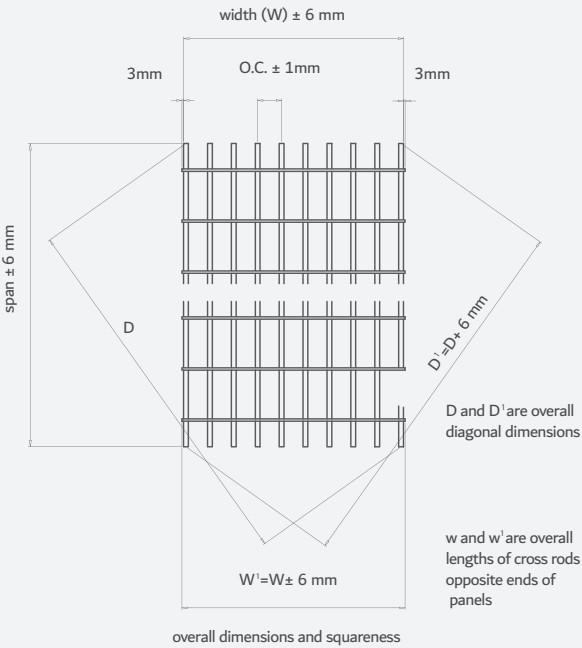

Stair tread tolerances

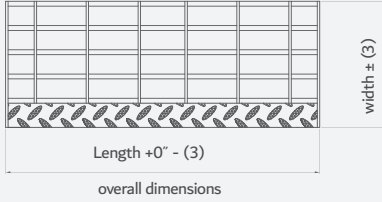

Note:
Length of tread is distance between outer faces of carrier plates or back to back of carrier angles.

Moshabak Sazan Arya

www.gratingmsa.ir



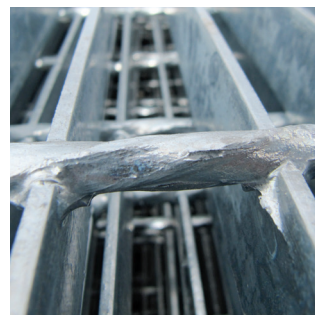
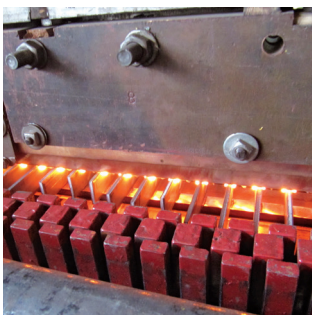

دستگاه تمام اتوماتیک ساخت گرتینگ (الکتروفورج)

فروش گرتینگ (الکتروفورج) به صورت پالت یک متر با قیمت بسیار مناسب برای دوستان و همکارانی که خود توانایی برش و نصب گرتینگ را دارا می باشد. (به صورت سیاه یا گالوانیزه شده)

یکی از کارکردهای و وظایف اصلی گریتهینگ تحمل بار می باشد که بر اساس میزان نیروی وارده بر گریتهینگ نوع تسمه و مشبندی داخلی انتخاب می گردد. در خصوص گریتهینگ دو نوع بارگذاری مورد نظر می باشد.

بار متمرکز:

اعمال نیرو در مرکز گریتهینگ با سطح مقطع ۱۰ سانتی متر در طول گریتهینگ می باشد.

بار گسترده:

که نیرو به صورت یکنواخت در سطح گریتهینگ اعمال می گردد.

One of the functions and main duty of grating is load carrying Which is selected based on grating received force belt type and inner meshing . two types of loading is considered for grating.

1. Centralized load

The received force in the center of grating 10 cm section area in grating length.

2. Distributed load

The uniform distributed force in the grating surface.

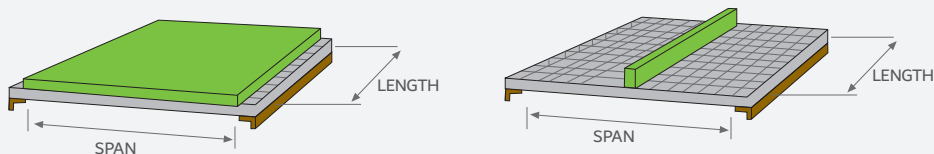

جدول مشخصات فنی ، وزن هر متر مربع و میزان تحمل بار رایج ترین نوع گریتهینگ ها

بار گسترده قابل تحمل kg/m ²	بار متمرکز قابل تحمل kg/m ²	وزن واحد kg	طول، عرض، ارتفاع mm	مشبندی mm	رابط	باربر	نوع گریتهینگ	کد کالا
1962	981	36.5	1000×1000×30	30×30	چهار پهلوی ۶×۶	30×3 mm	گریتهینگ تسمه در چار پهلو	MSA-303B33
1962	981	33.5	1000×1000×30	30×50	چهار پهلوی ۶×۶	30×3 mm	گریتهینگ تسمه در چار پهلو	MSA-303B35
1962	981	31.1	1000×1000×30	30×100	چهار پهلوی ۶×۶	30×3 mm	گریتهینگ تسمه در چار پهلو	MSA-303B31
2539	1269	49.7	1000×1000×30	30×30	چهار پهلوی ۶×۶	30×4 mm	گریتهینگ تسمه در چار پهلو	MSA-304B33
2539	1269	44.5	1000×1000×30	30×50	چهار پهلوی ۶×۶	30×4 mm	گریتهینگ تسمه در چار پهلو	MSA-304B35
2539	1269	40.5	1000×1000×30	30×100	چهار پهلوی ۶×۶	30×4 mm	گریتهینگ تسمه در چار پهلو	MSA-304B31
3038	1541	51.8	1000×1000×30	30×30	چهار پهلوی ۶×۶	30×5 mm	گریتهینگ تسمه در چار پهلو	MSA-305B33
3038	1541	48.8	1000×1000×30	30×50	چهار پهلوی ۶×۶	30×5 mm	گریتهینگ تسمه در چار پهلو	MSA-305B35
3038	1541	46.5	1000×1000×30	30×100	چهار پهلوی ۶×۶	30×5 mm	گریتهینگ تسمه در چار پهلو	MSA-305B31
19621	981	37	1000×1000×30	30×30	10 × 3 mm	30×3 mm	گریتهینگ تسمه در نیم تسمه	MSA-303C33
962	981	33.7	1000×1000×30	30×50	10 × 3 mm	30×3 mm	گریتهینگ تسمه در نیم تسمه	MSA-303C35
19622	981	31.3	1000×1000×30	30×100	10 × 3 mm	30×3 mm	گریتهینگ تسمه در نیم تسمه	MSA-303C31
539	1269	41.4	1000×1000×30	30×50	10 × 3 mm	30×4 mm	گریتهینگ تسمه در نیم تسمه	MSA-304C35
2539	1269	39	1000×1000×30	30×100	10 × 3 mm	30×4 mm	گریتهینگ تسمه در نیم تسمه	MSA-304C31
3083	1541	49	1000×1000×30	30×50	10 × 3 mm	30×5 mm	گریتهینگ تسمه در نیم تسمه	MSA-305C35
3083	1541	46.6	1000×1000×30	30×100	10 × 3 mm	30×5 mm	گریتهینگ تسمه در نیم تسمه	MSA-305C31

این جدول فقط برای نمونه های واحد یک متر در یک متر ارائه شده است در صورت لزوم از نرم افزار این شرکت جهت ابعاد متغیر یا سایزهای دیگری از تسمه استفاده نمایید.

Wheel loads

For slow moving wheel loads and taking into account an impact factor it is generally accepted that deflections in excess of B.S recommendations for pedestrian loading are a sub-ordinate consideration provided that the loadings imposed do not allow the maximum permitted stress to be exceeded

Pneumatic

Representing a uniformly distributed load over part of the clear span . the worst cases being

- A.** Wheel at mid span
- B.** Travelling along loadbearing bars when the tread width X is less than or equal to the tread length L.
- C.** When the load is applied over double wheels, which effectively increases the tread width, to more than the tread length, and with the wheels travelling across the load bearing bars as shown below, in this case the bearing are represented by overall width L by tread length X
- D.** When the load is applied over double wheels, which effectively increases the tread width, to more than the tread length, and with the wheels travelling across the load bearing bars as shown below, in this case the bearing are represented

- I.F. = Impact factor 1.25
- F = Safe working stress 165000 Kn/m²
- F max = Maximum permitted working stress
F X 1.1 = 181500 kN/m²
- M max = Maximum bending moment (when W includes I.F.)
 $\frac{WS}{4} - \frac{W}{8}$ (kNm)
- I = Moment of inertia per tread = BD³
- 12 x N (m⁴) [n = $\frac{\text{no.of bars}}{\text{carrying load}} = \frac{x}{p}$]
- F. actual = $\frac{My}{I}$ kN/m² [y = D/2 & M includes I.F.]
- δ. = Actual deflection = $\frac{5wx^2(s-l-2)}{192EI}$ (m)
- W = Total load (kN) excluding I.F.
- s = CLEAR SPAN (m)
- e = Young's modulus of elasticity 2.0684 x 10⁸ kN/m²

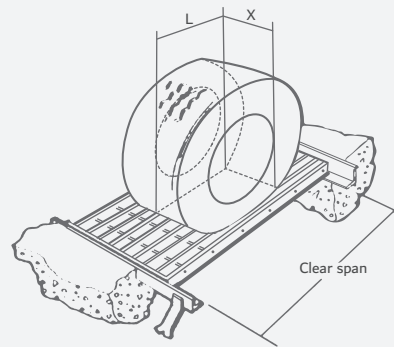

Solid

Representing a point load over one or more loadbearing bars, depending on width of wheel. The worst case being when moving across the loadbearing bars, at mid span

- I.F. = impact factor 1.25
- F = Safe working stress 165000 kN/m²
- F max = Maximum permitted working stress
F x 1.1 = 181500 kN/m²
- M max = Maximum bending moment (when W includes I.F.)
 $\frac{WS}{4}$ (kNm)
- W = Total load (kN) excluding I.F.
- S = Clear span (m)
- F . actual = Stress produced by load + I . F . = $\frac{MY}{I^1}$ kN/m²
- Y = Extreme fibre distance = $\frac{D}{2}$ (m)
- E = Young s modulus of elasticity 2.0684 x 10⁸ kN/m²
- I = Moment of inertia per tread = $\frac{BD^3}{2}$ (m⁴)
- B = Load bearing bar breadth(m)
- D = load bearing bar depth(m)
- A = actual deflection = $\frac{WS^3}{48EI}$
- N = number of load bearing bars actually loaded
(use 1xn for I¹ when calculating „o” and „F . actual”)

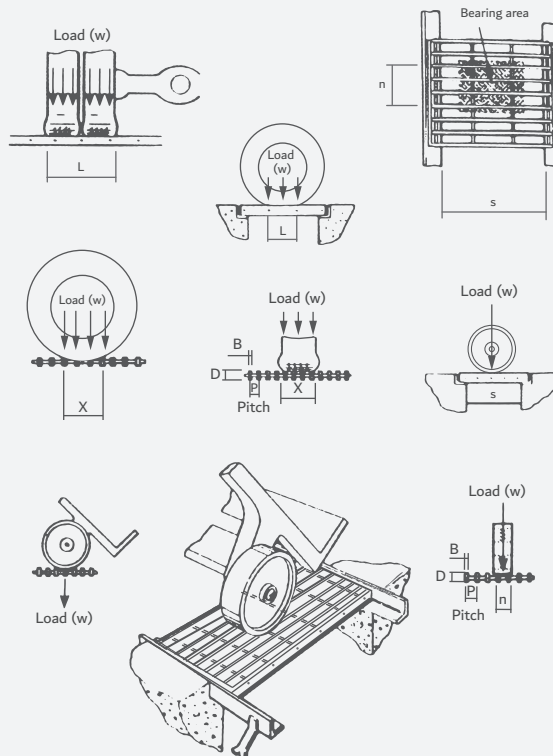

Note: The grating illustrated is the Moshabak Sazan manually made grating Which has 8 mm dia. cross bars threaded through the loadbearing bars and tack welded into position. cross bars are usually 15mm down from top surface of grating.

Tread dimensions

Recommended details

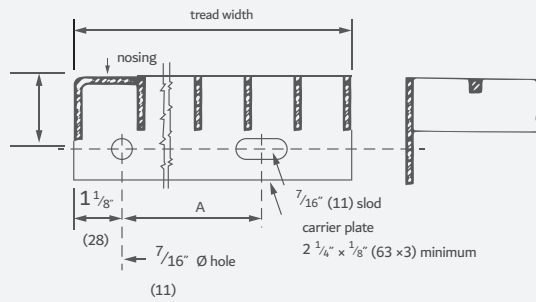

TREAD with carrier plate detail
 TREAD with carrier angles available consult grating manufacturer for detail

DIMENSION A in TREAD with carrier plate detail in (mm)

Nominal Tread Width (approximate)** Bearing Bar Centers		Dimension A
1 3/16 (30)	15/16 (24)	
6 1/4 (159)	6 (152)	2 1/2 (63)
7 1/4 (184)	7 (178)	4 1/2 (114)
8 1/2 (216)	9 (229)	4 1/2 (114)
9 3/4 (248)	10 (254)	7 (178)
11 (279)	10 3/4 (273)	7 (178)
12 (305)	11 (298)	7 (178)

** Consult manufacturer for exact dimension

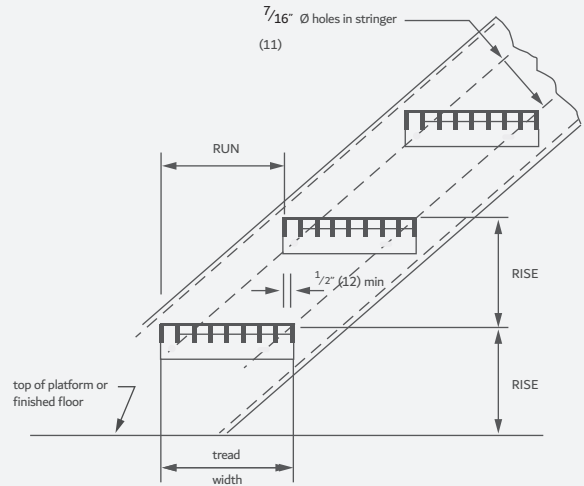

Note: Tread width should always be greater than tread run by 1/2 in. (12 mm) minimum

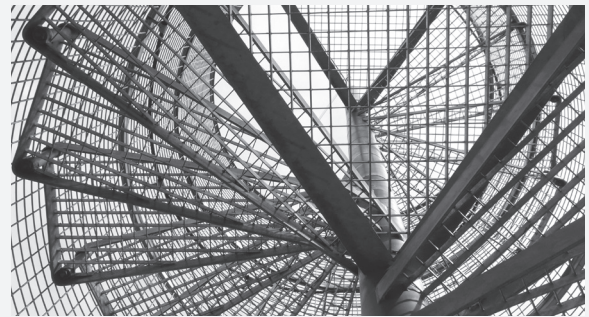

Standard installation clearances

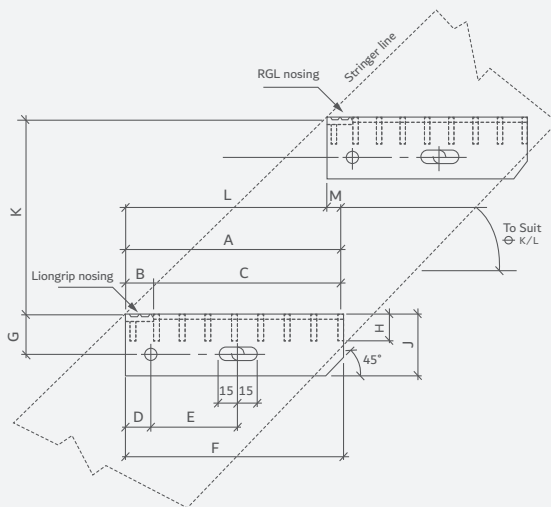

- A** - Tread width
- B** - Nosing width
- C** - Grating center width
- D** - Hole distance from front side
- E** - Center to center distance between holes
- F** - End plate width
- G** - Hole distance from top
- H** - Bearing bar depth
- J** - End plate height
- K** - Tread rise
- L** - Tread going
- M** - Overlap (min. 16mm)

Note: rear corner of tread and plate sniped off as shown, unless marked thus *front fixing hole 14 dia. rear fixing hole 14 dia. rear fixing hole 14 x30 slot. Unless noted notead otherwise, tread end plate 70x5 M.S.flat.

All grating are to be firmly anchored to their supports by positive means.

One weld in middle of panel at each intermediate support

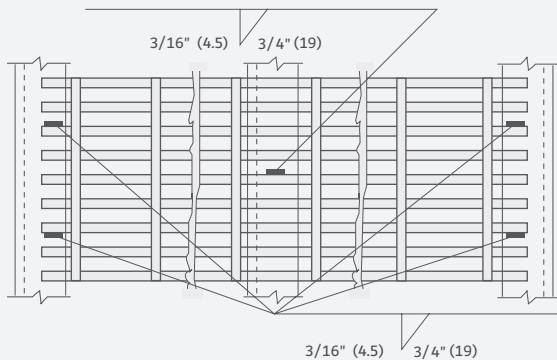

1. Welded Anchorage (in field by others)

Recommended for all permanently installed gratings.

Welds at ends of bearing bar approximately 6 inches from each side of panel

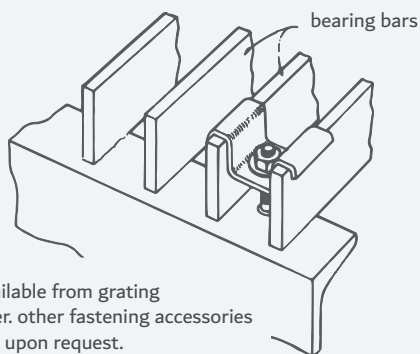

Clips are available from grating manufacturer. other fastening accessories are available upon request.

2. Saddle Clips

Available in steel, stainless steel, and aluminum (it is sometimes necessary to cut cross bars during installation for fastener clearance). Used for installations. Will be in same location as welds in **1** unless otherwise specified. Fasteners are 1 /4 in (6.4 mm) diameter.

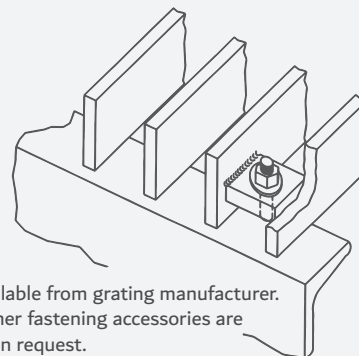

Lugs are available from grating manufacturer. Bolts and other fastening accessories are available upon request.

3. Weldlugs

Shop welded to bearing bars must be specified when ordering . Used for installations where grating is subject to removal. Will be in same location as welds in **1** unless otherwise specified. Fasteners are 1/4 in. (6.4 mm) diameter.

4. Other Types

Other types of anchors which have been appropriately tested and have demonstrated satisfactory performance may be used also. Included in other types are top-mounting mechanical friction anchors which can be installed without requiring access to the underside of the grating and which eliminate field welding and/or drilling. These anchors are removable and may be used where gratings are subject to frequent removal.



برخی از مشتریان این شرکت



location map of moshabak sazan aria

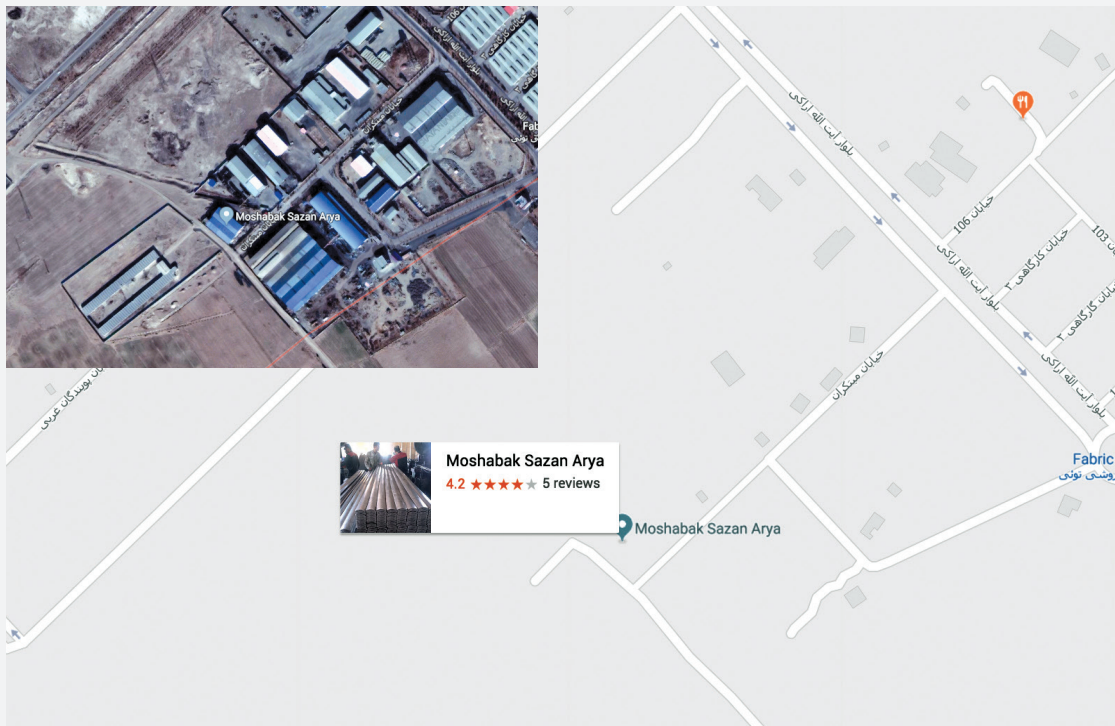

جای پاتو محکم کن





اراک، شهرک صنعتی خیرآباد، خیابان صنعتگران غربی
انتهای خیابان ۱۰۲ کد پستی: ۳۸۳۷۱۴۳۵۹۵
تلفن: ۱۲-۳۳۵۳۶۱۰-۰۸۶ (۰۸۶) فکس: ۳۳۵۳۲۰۷-۰۸۶

St. No 102, kheirabad industrial city, Arak, Iran
P.O.Box: 3837143595
Tel: (+98 86) 33553610 -12
Fax: (+98 86) 33553207

Moshabak Sazan Arya

| Grating & Stair Tread



شرکت مشبک سازان آریا



Moshabak Sazan Arya

Grating & Stair Tread

Moshabak Sazan Arya

Grating & Stair Tread